



G4260.06-113-11-R0
ACOUSTICAL PERFORMANCE TEST REPORT
ASTM E 90 AND ASTM E 492

Rendered to

US ARCHITECTURAL PRODUCTS, INC.

Series/Model: Plycem CemDeck with Double Layer Ceiling - Shaw LVT

Specimen Type: Open Web Truss - 356 mm

Overall Size: 3023 mm by 3632 mm

STC 55
IIC 43

Test Specimen Identification:

Floor Topping: 3.06 mm Shaw Resilient Classico Luxury Vinyl Tile

Subfloor: 20 mm Plycem CemDeck Cement Board Floor Panels

Insulation: 101.6 mm 4 PCF Rock Wool Insulation

Joist: 254 mm 8J16 Steel Floor Joists

Ceiling Isolation: 22.3 mm ClarkDietrich 087F125-18 Furring/Hat Channel

Ceiling: 15.9 mm USG SHEETROCK® Brand FIRECODE® C Core Gypsum Panel

Ceiling: 15.9 mm USG SHEETROCK® Brand FIRECODE® C Core Gypsum Panel

Reference should be made to Intertek-ATI Report G4260.06-113-11 for complete test specimen description. This page alone is not a complete report.



Acoustical Performance Test Report

US ARCHITECTURAL PRODUCTS, INC.
103 Carnegie Center, Suite 320
Princeton, New Jersey 08540

Report G4260.06-113-11
Test Date 11/28/16
Report Date 12/16/16

Project Scope

Architectural Testing, Inc., an Intertek company (Intertek-ATI), was contracted to conduct airborne sound transmission loss and impact sound transmission tests. The complete test data is included as attachments to this report. The full test specimen was assembled on the day of testing by Intertek-ATI. All materials provided by the client were installed on an existing Intertek-ATI assembly (Open Web Truss - 356 mm) utilizing Intertek-ATI-supplied materials.

Test Methods

The acoustical tests were conducted in accordance with the following standards. The equipment listed in the attachments meets the requirements of the following standards.

ASTM E 90-09, Standard Test Method for Laboratory Measurement of Airborne Sound Transmission Loss of Building Partitions

ASTM E 413-10, Classification for Rating Sound Insulation

ASTM E 492-09(2016)e1, Standard Test Method for Laboratory Measurement of Impact Sound Transmission Through Floor-Ceiling Assemblies Using the Tapping Machine

ASTM E 989-06 (2012), Classification for Determination of Impact Insulation Class (IIC)

ASTM E 2235-04 (2012) Standard Test Method for Determination of Decay Rates for Use in Sound Insulation Test Methods

Test Procedure

All testing was conducted in the VT test chambers at Intertek-ATI located in York, Pennsylvania. The microphones were calibrated before conducting the tests.

The airborne transmission loss test was conducted in accordance with the ASTM E 90 test method using the single direction method. Two background noise sound pressure level and five sound absorption measurements were conducted at each of five microphone positions. Four sound pressure level measurements were made simultaneously in both rooms, at each of five microphone positions.

Test Procedure (Continued)

The impact sound transmission test was conducted in accordance with the ASTM E 492 test method. Two background noise sound pressure level, two sound pressure level measurements with the tapping machine operating at each position specified by ASTM E 492, and five sound absorption measurements were conducted at each of five microphone positions.

The air temperature and relative humidity conditions were monitored and recorded during all measurements.

Test Conditions

Source Room		Receive Room	
Average Temperature	19.8°C	Average Temperature	16.7°C
Average Relative Humidity	46%	Average Relative Humidity	45%

Test Calculations

The STC (Sound Transmission Class) and IIC (Impact Insulation Class) ratings were calculated in accordance with ASTM E 413 and ASTM E 989, respectively.

Test Specimen Materials and Installation Details

Material	Dimensions (mm)	Thickness (mm)	Manufacturer and Series	Quantity	Average Weight
Luxury Vinyl Tile	152.4 by 1219	3.1	Shaw Resilient Classico	10.98 m ²	5.96 kg/m ²
	<i>Note: Loose laid</i>				
Cement Board Floor Panels	1219 by 2348	20.0	Plycem CemDeck	10.98 m ²	23.92 kg/m ²
	<i>Note: Fastened to the joists with 47.6 mm #8 screws on 305 mm centers along perimeter and 406 mm centers along trusses</i>				
Rock Wool Insulation	609.6 by 1219	101.6	4 PCF	10.98 m ²	3.25 kg/m ²
	<i>Note: Installed in the cavity between joists flush with the subfloor. Hanger wire was used to keep insulation secure on 305 mm</i>				
Steel Floor Joists	2889 by 42.5	254.0	8J16	7 joist	23.21 kg/joist
	<i>Note: Installed on 610 mm centers using JUS414 hanger brackets.</i>				
Furring/Hat Channel	3658 by 76.2	22.3	ClarkDietrich 087F125-18	29.1 lin m	0.48 kg/m
	<i>Note: Fastened to the bottom flangers of the joists, spaced 406 mm on center.</i>				
Gypsum Panel	1219 by 3023	15.9	USG SHEETROCK® Brand FIRECODE® C Core	10.98 m ²	11.9 kg/m ²
	<i>Note: Fastened to the channels on 305 mm centers with 25.4 mm Type S bugle head screws. The seams of the gypsum panels were sealed with Pecora AC-20 FTR caulk and covered with pressure sensitive tape.</i>				
Gypsum Panel	1219 by 3023	15.9	USG SHEETROCK® Brand FIRECODE® C Core	10.98 m ²	11.9 kg/m ²
	<i>Note: Fastened to the channels on 305 mm centers with 31.8 mm Type S bugle head screws. The seams of the gypsum panels were sealed with Pecora AC-20 FTR caulk and covered with pressure sensitive tape.</i>				

Comments

The total weight of the floor/ceiling assembly was 801.7 kg. Intertek-ATI will store samples of the test specimen for four years. Photographs of the test specimen are included in the attachments. A drawing of the test specimen is included in the attachments.

Intertek-ATI will service this report for the entire test record retention period. Test records, such as detailed drawings, datasheets, representative samples of test specimens, or other pertinent project documentation, will be retained by Intertek-ATI for the entire test record retention period. The test record retention period ends four years after the test date.

This report does not constitute certification of this product nor an opinion or endorsement by this laboratory. It is the exclusive property of the client so named herein and relates only to the specimen tested. This report is intended to help in the client's quality assurance program, but it does not represent a continuous or exhaustive evaluation of the specimen tested or of other products or materials that were not evaluated. The statements and data provided herein do not constitute approval, disapproval, certification, or acceptance of performance or materials.

This report may not be reproduced, except in full, without the written approval of Intertek-ATI.

FOR INTERTEK-ATI:

Cody R. Snyder
Technician II - Acoustical Testing

Jordan Strybos
Project Manager - Acoustical Testing

Attachments (7 pages): This report is complete only when all attachments listed are included.

- Instrumentation (1)
- Airborne Sound Transmission Loss Data (2)
- Impact Sound Transmission Data (2)
- Photographs (1)
- Drawings (1)

** Stated by Client/Manufacturer*

N/A - Non Applicable



Revision Log

<u>Revision</u>	<u>Date</u>	<u>Page(s)</u>	<u>Description</u>
R0	12/16/16	N/A	Original Report Issue

Attachments

Instrumentation

Instrument	Manufacturer	Model	ATI Number	Date of Calibration
Data Acquisition Unit	National Instruments	PXI-1033	65124	06/16 *
Microphone Calibrator	Norsonic	1251	INT00127	01/16
Receive Room Microphone	PCB Piezotronics	378B20	63748	06/16
Receive Room Microphone	PCB Piezotronics	378B20	63744	06/16
Receive Room Microphone	PCB Piezotronics	378B20	63745	06/16
Receive Room Microphone	PCB Piezotronics	378C20	65617	06/16
Receive Room Microphone	PCB Piezotronics	378B20	63747	06/16
Receive Room Environmental Indicator	Comet	T7510	63810	10/16
			63811	10/16
Source Room Microphone	PCB Piezotronics	378B20	63738	05/16
Source Room Microphone	PCB Piezotronics	378B20	63739	05/16
Source Room Microphone	PCB Piezotronics	378B20	63740	05/16
Source Room Microphone	PCB Piezotronics	378B20	63742	05/16
Source Room Microphone	Scantek	378B20	63741	05/16
Source Room Environmental Indicator	Comet	T7510	63812	11/16
Tapping Machine	Look Line s.r.l.	EM50 (TM50)	65351	02/16

* The calibration frequency for this equipment is every two years per the manufacturer's recommendation.

Test Chambers

VT Receive Room Volume	157.31 m ³
VT Source Room Volume	190 m ³



G4260.06-113-11-R0

AIRBORNE SOUND TRANSMISSION LOSS

ASTM E 90



Test Date	11/28/16
Data File No.	G4260.06
Client	US Architectural Products, Inc.
Description	3.06 mm Shaw Resilient Classico Luxury Vinyl Tile , 20 mm Plycem CemDeck Cement Board Floor Panels, 101.6 mm 4 PCF Rock Wool Insulation, 254 mm 8J16 Steel Floor Joists, 22.3 mm ClarkDietrich 087F125-18 Furring/Hat Channel, 15.9 mm USG SHEETROCK® Brand FIRECODE® C Core Gypsum Panel, 15.9 mm USG SHEETROCK® Brand FIRECODE® C Core Gypsum Panel
Specimen Area	10.98 m ²
Technician	Cody R. Snyder

Freq (Hz)	Background SPL (dB)	Absorption (m ²)	Source SPL (dB)	Receive SPL (dB)	Specimen TL (dB)	95% Confidence Limit	Number of Deficiencies
80	31.4	17.8	108	78	27	3.20	-
100	30.8	12.6	107	77	29	2.50	-
125	28.9	10.3	104	69	35	1.70	4
160	23.3	10.1	105	65	40	1.10	2
200	20.4	10.7	104	59	45	1.00	0
250	25.5	9.9	103	55	48	0.50	0
315	19.7	9.3	105	57	49	0.90	2
400	16.3	8.5	103	53	51	0.70	3
500	25.0	7.6	102	51	53	0.40	2
630	19.2	7.6	102	51	53	0.40	3
800	19.6	7.7	102	50	54	0.40	3
1000	19.7	7.6	102	48	55	0.20	3
1250	15.4	7.6	100	44	58	0.30	1
1600	11.6	7.7	100	45	57	0.30	2
2000	7.5	8.4	100	47	54	0.30	5
2500	5.6	9.4	96	38	59	0.40	0
3150	5.5	10.2	98	32	66	0.40	0
4000	6.1	12.2	98	28	70	0.50	0
5000	7.1	14.3	95	22	72	0.60	-
6300	8.3	17.6	93	13	77	0.50	-
8000	8.3	23.9	93	11	79	0.60	-
10000	8.3	29.9	91	8	78	0.80	-

STC Rating **55** (*Sound Transmission Class*)

Deficiencies **30** (*Sum of Deficiencies*)

- Notes:**
- 1) Receive Room levels less than 5 dB above the Background levels are highlighted in yellow.
 - 2) Specimen TL levels listed in *red* are potentially limited by the laboratory flanking limit.
 - 2) Specimen TL levels listed in *blue* indicate the lower limit of the transmission loss.
 - 3) Specimen TL levels listed in *green* indicate that there has been a filler wall correction applied

AIRBORNE SOUND TRANSMISSION LOSS
ASTM E 90

Test Date	11/28/16
Data File No.	G4260.06
Client	US Architectural Products, Inc.
Description	3.06 mm Shaw Resilient Classico Luxury Vinyl Tile , 20 mm Plycem CemDeck Cement Board Floor Panels, 101.6 mm 4 PCF Rock Wool Insulation, 254 mm 8J16 Steel Floor Joists, 22.3 mm ClarkDietrich 087F125-18 Furring/Hat Channel, 15.9 mm USG SHEETROCK® Brand FIRECODE® C Core Gypsum Panel, 15.9 mm USG SHEETROCK® Brand FIRECODE® C Core Gypsum Panel
Specimen Area	10.98 m ²
Technician	Cody R. Snyder

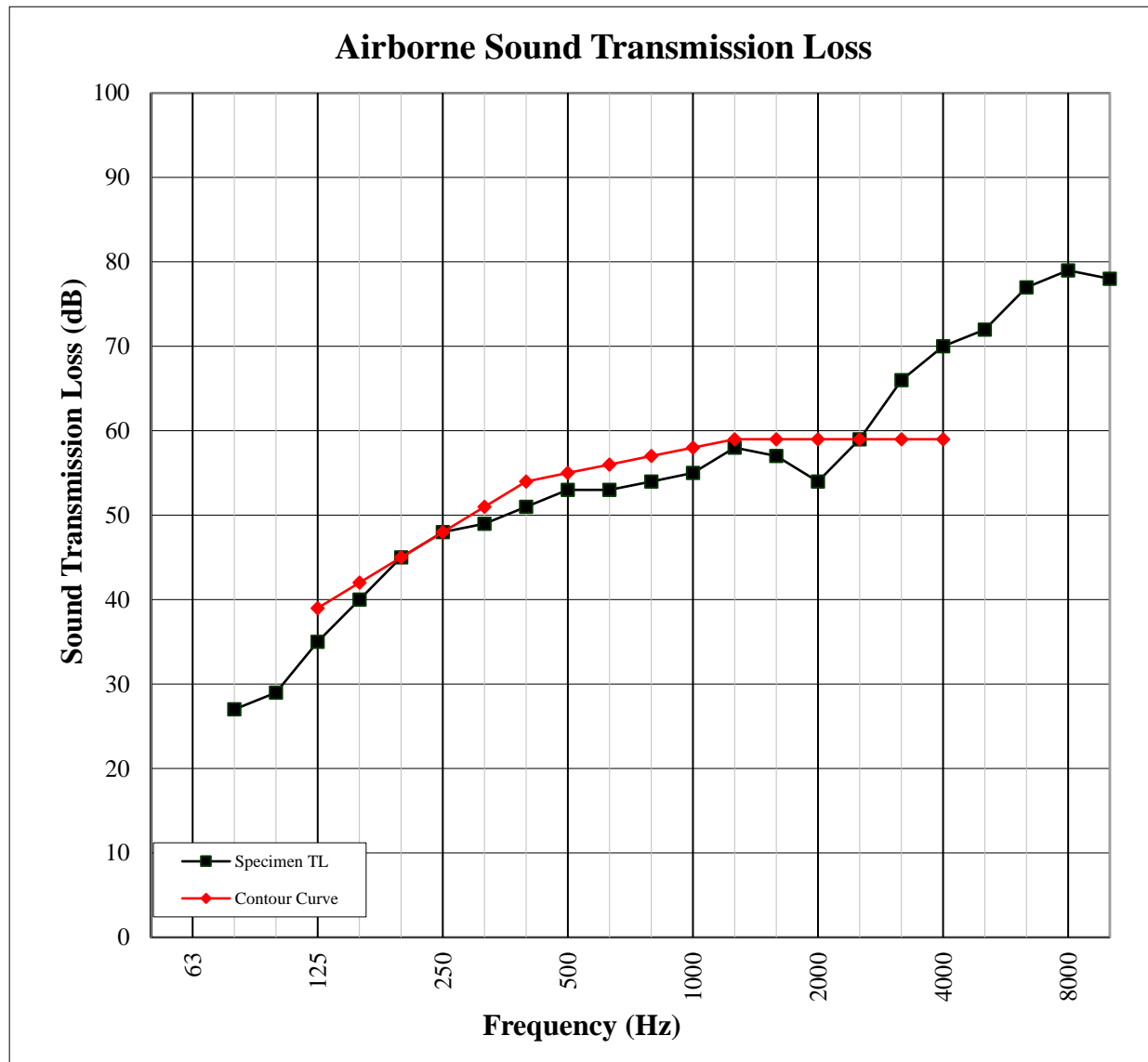



G4260.06-113-11-R0



IMPACT SOUND TRANSMISSION
ASTM E 492

Test Date	11/28/16
Data File No.	G4260.06
Client	US Architectural Products, Inc.
Description	3.06 mm Shaw Resilient Classico Luxury Vinyl Tile , 20 mm Plycem CemDeck Cement Board Floor Panels, 101.6 mm 4 PCF Rock Wool Insulation, 254 mm 8J16 Steel Floor Joists, 22.3 mm ClarkDietrich 087F125-18 Furring/Hat Channel, 15.9 mm USG SHEETROCK® Brand FIRECODE® C Core Gypsum Panel, 15.9 mm USG SHEETROCK® Brand FIRECODE® C Core Gypsum Panel
Specimen Area	10.98 m ²
Technician	Cody R. Snyder

Freq (Hz)	Background SPL (dB)	Absorption (m ²)	Normalized Impact SPL (dB)	95% Confidence Limit	Number of Deficiencies
80	34.9	17.7	70	3.3	-
100	26.5	14.3	71	2.5	2
125	28.6	10.2	71	2.8	2
160	22.8	9.6	73	1.7	4
200	19.5	10.8	70	1.2	1
250	25.7	10.4	69	1.5	0
315	18.9	9.6	70	0.6	1
400	15.9	8.4	70	0.7	2
500	25.1	7.6	69	0.7	2
630	18.6	7.6	69	0.6	3
800	20.7	7.8	66	0.3	1
1000	17.6	7.6	65	0.5	1
1250	14.0	7.7	61	0.1	0
1600	10.2	7.8	60	0.3	2
2000	6.3	8.6	60	0.3	5
2500	4.7	9.4	55	0.1	3
3150	4.6	10.3	49	0.4	0
4000	5.0	12.1	44	0.3	-
5000	5.7	14.0	39	0.6	-
6300	6.3	17.7	34	0.9	-
8000	6.8	23.9	30	1.5	-
10000	7.1	29.6	27	1.8	-

IIC Rating **43** *(Impact Insulation Class)*

Deficiencies **29** *(Sum of Deficiencies)*

Note: *Receive Room levels less than 5 dB above the Background levels are highlighted in yellow.*

IMPACT SOUND TRANSMISSION
ASTM E 492

Test Date	11/28/16
Data File No.	G4260.06
Client	US Architectural Products, Inc.
Description	3.06 mm Shaw Resilient Classico Luxury Vinyl Tile , 20 mm Plycem CemDeck Cement Board Floor Panels, 101.6 mm 4 PCF Rock Wool Insulation, 254 mm 8J16 Steel Floor Joists, 22.3 mm ClarkDietrich 087F125-18 Furring/Hat Channel, 15.9 mm USG SHEETROCK® Brand FIRECODE® C Core Gypsum Panel, 15.9 mm USG SHEETROCK® Brand FIRECODE® C Core Gypsum Panel
Specimen Area	10.98 m ²
Technician	Cody R. Snyder

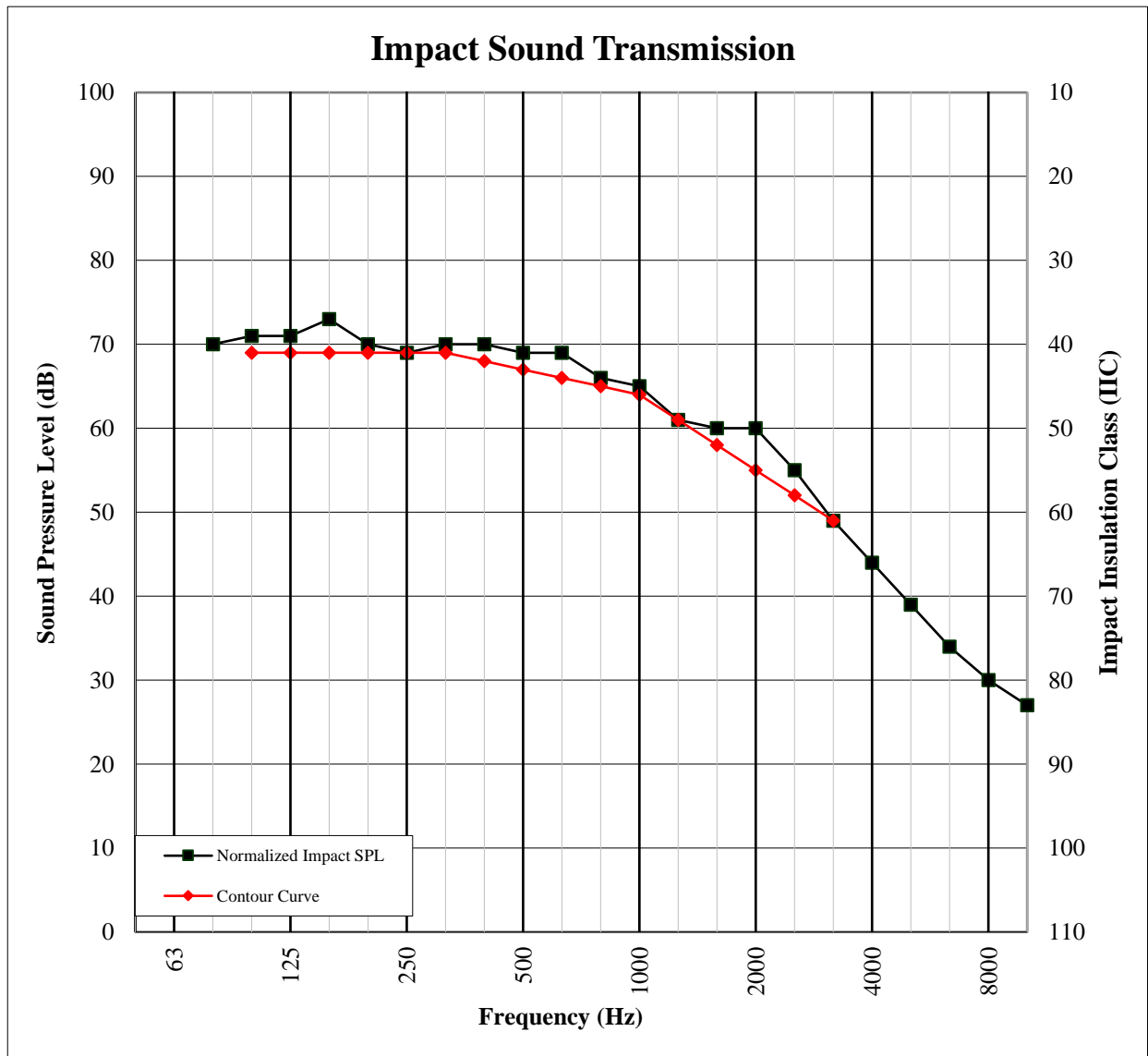

Photographs



Close-Up of Test Specimen



Receive Room View of Test Specimen Installation

Drawing

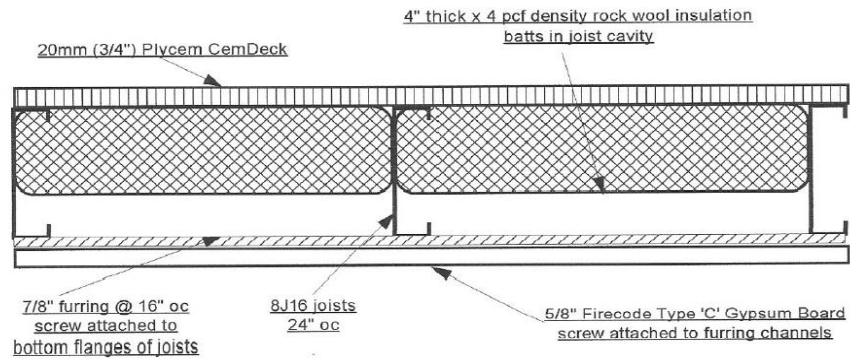

Cross Section of Assembly

(single ceiling layer shown - second layer was installed for test)